

# PowerFlo

**ABOVE-GROUND-POOL PUMP SERIES**

# LX™

- Designed specifically for the rigors of above-ground- and on-ground-type swimming pools
- Provides dependable, energy-efficient performance and quiet operation
- Extra-large debris basket keeps pool maintenance to a minimum
- Made of our exclusive PermaGlass XL™ material for years of total pool-owner satisfaction



# ABOVE-GROUND POOL PUMP SERIES

The Hayward PowerFlo LX high-performance-pump series is designed specifically for the rigors of above-ground- and on-ground-type swimming pools. Featuring a heavy-duty motor, PowerFlo LX offers dependable performance and quiet operation. An extra-large debris basket keeps pool maintenance to a minimum, letting you enjoy your pool more. And because PowerFlo LX is made of our exclusive high-strength PermaGlass XL™ material, it will provide years of total pool satisfaction. Dependable, quiet and energy efficient, the PowerFlo LX pump series continues to set the standard for value and performance.

## PowerFlo LX Specifications

Model	HP	Inlet/Outlet	Description
SP1580	1	1½"	PowerFlo LX pump with strainer
SP1580TL	1	1½"	PowerFlo LX pump with strainer and twist-lock cord
SP1580X15	1½	1½"	PowerFlo LX pump with strainer
SP1580X15TL	1½	1½"	PowerFlo LX pump with strainer and twist-lock cord

"TL" pump includes 3' twisting lock cord.



*Super-size 118-cubic-inch basket has extra leaf-holding capacity and extends time between cleanings. Rigid construction with load-extender ribbing ensures free-flowing operation for heavy debris loads.*

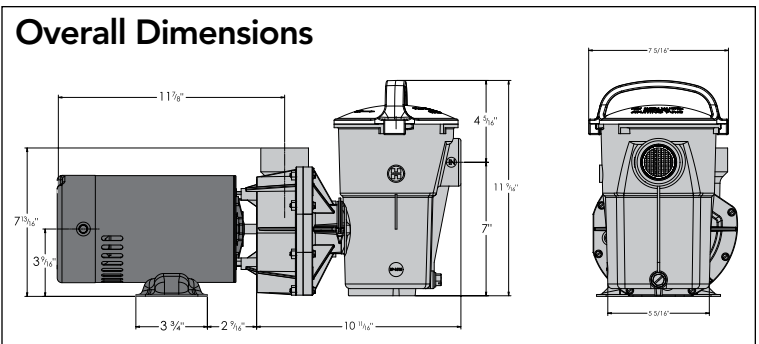

**HAYWARD** Pool Products

*One source. Every pool.*

[www.haywardnet.com](http://www.haywardnet.com)